

ABB monitoring and communications VSN300 Wifi Logger Card

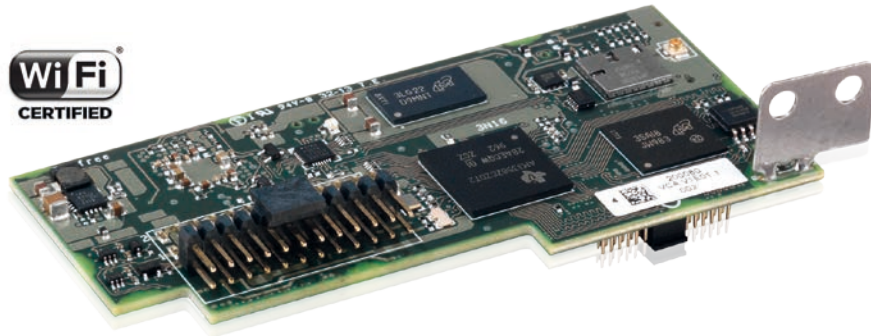

The VSN300 Wifi Logger Card is a new, advanced expansion board for ABB's UNO and TRIO string inverters which provides residential and commercial users with an advanced and cost-effective solution for monitoring and controlling their photovoltaic system.

The VSN300 Wifi Logger Card is easy to install, for new and most existing string inverters by using the inverter's internal expansion slot.

The built-in IP networking connectivity and innovative Wi-Fi commissioning techniques enable this card to be easily configured for most Wi-Fi networks and access points without installing any additional external devices.

Complete, remote and local monitoring with Wifi Logger Card and new free mobile app.

Users have a complete remote and local monitoring experience when combining VSN300 Wifi Logger Card with ABB's new free mobile app; "Plant Viewer for Mobile". It is available for both iOS and Android based devices.

The local web server in VSN300 Wifi Logger Card adds the ability to use a standard web browser to access inverter data.

The Wi-Fi Certified™ mark assures interoperability, security, easy installation, and reliability. With innovative commissioning and upgrade features, the VSN300 Wifi Logger Card provides the best user experience for ABB's customers.

Not only is the VSN300 Wifi Logger Card suitable for most of ABB's string inverters currently deployed, it takes advantage of the Hyperlink bus found in new inverters for obtaining real-time data that can be used for grid control power management.

Highlights

- The Wi-Fi Certified™ mark assures interoperability with IEEE 802.11b/g/n networks over the 2.4GHz band
- Easily installed on new and existing UNO and TRIO string inverters
- IEEE 802.11b/g/n (2.4 GHz) support
- Local, remote monitoring in one solution
- High performance non-volatile data logging
- High-speed inverter data exchange through Hyperlink [where available]
- Modbus TCP server for SCADA integration
- SunSpec certified Modbus mapping for easy integration
- Secured and encrypted data transfer to Aurora Vision® Plant Management Platform

Additional highlights

- Remote reading and writing of inverter parameters for advanced operations
- California Rule 21 ready



Technical data and types

Type code	VSN300 Wifi Logger Card
Communication interfaces	
Inverter interface	Hyperlink (CAN@1 Mbps + RS485@115 kBaud) / Legacy (RS232 TTL @ 19.2 kBaud)
User interface	Wi-Fi Certified™ IEEE 802.11 b/g/n (2,4 GHz)
Communication protocols	
Protocols LAN/WAN	HTTPS, DHCP, NTP, SSL, SSH, XML, Modbus TCP (Sunspec)
Monitoring	
Web user interface (WUI)	Integrated
Local monitoring	wirelessly allowed via any Wi-Fi® device connecting the integrated WUI or running Plant Viewer ^{for mobile}
Remote monitoring	Plant Portfolio Manager® / Plant Viewer™ / Plant Viewer ^{for mobile}
Data logging specifications	
Data sampling rate	High frequency data sampling (less than 1 minute average)
Local data storage	Log data for 30 days based on 15-minute intervals
Upgradeability	Remotely via Aurora Vision® Plant Management Platform / Locally via Web User Interface
Advanced functionalities	
Remote O&M operations	Inverter's parameters changing / Inverter's firmware upgrade
Smart grid functionalities	Grid control power-management enabled
Power supply	
DC power supply output	~ 2W
Environmental parameters	
Ambient temperature range	[-20; +85] °C
Environmental protection	IP 20
Relative humidity	<85% Non-condensing
Mechanical parameters (per unit)	
Dimensions (H x W x D)	3.81' x 1.81' x 0.63' (97 mm x 46mm x 16mm)
Weight	0.06 lbs (26g)
Mounting System	inverter's expansion slot
Compliance	
Marking	CE / FCC / RCM / Wi-Fi Certified™
Emissions	FCC Part 15 Class B, CISPR 22, EN 55022 Conducted and radiated emission
Immunity	EN55024

Remark. Features not specifically listed in the present data sheet are not included in the product

Application with VSN300 Wifi Logger Card

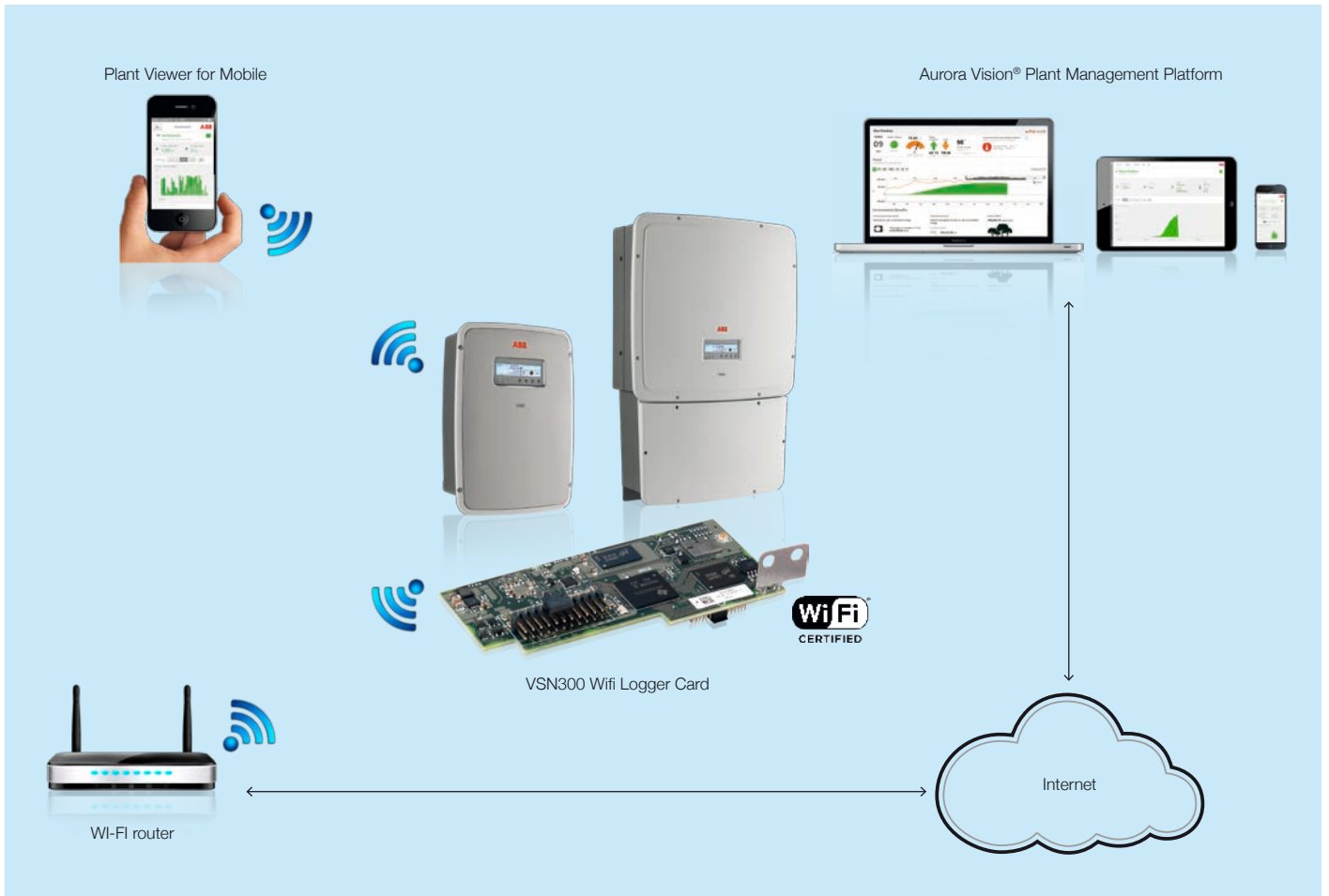

Inverter matrix compatibility

Inverter family	Monitoring	Remote O&M Operations
UNO-2.0	Yes	No
UNO-2.5	Yes	No
PVI-3.0	Yes	No
PVI-3.6	Yes	No
PVI-3.8	Yes	No
PVI-4.2	Yes	No
PVI-4.6	Yes	No
PVI-5000	Yes	No
PVI-6000	Yes	No
PVI-6.0	Yes	No
PVI-8.0	Yes	No
PVI-10.0	Yes	No
PVI-12.5	Yes	No
TRIO-5.8	Yes	Yes
TRIO-7.5	Yes	Yes
TRIO-8.5	Yes	Yes
TRIO-20	Yes	No
TRIO-27.6	Yes	No

Block diagram of VSN300 Wifi Logger Card

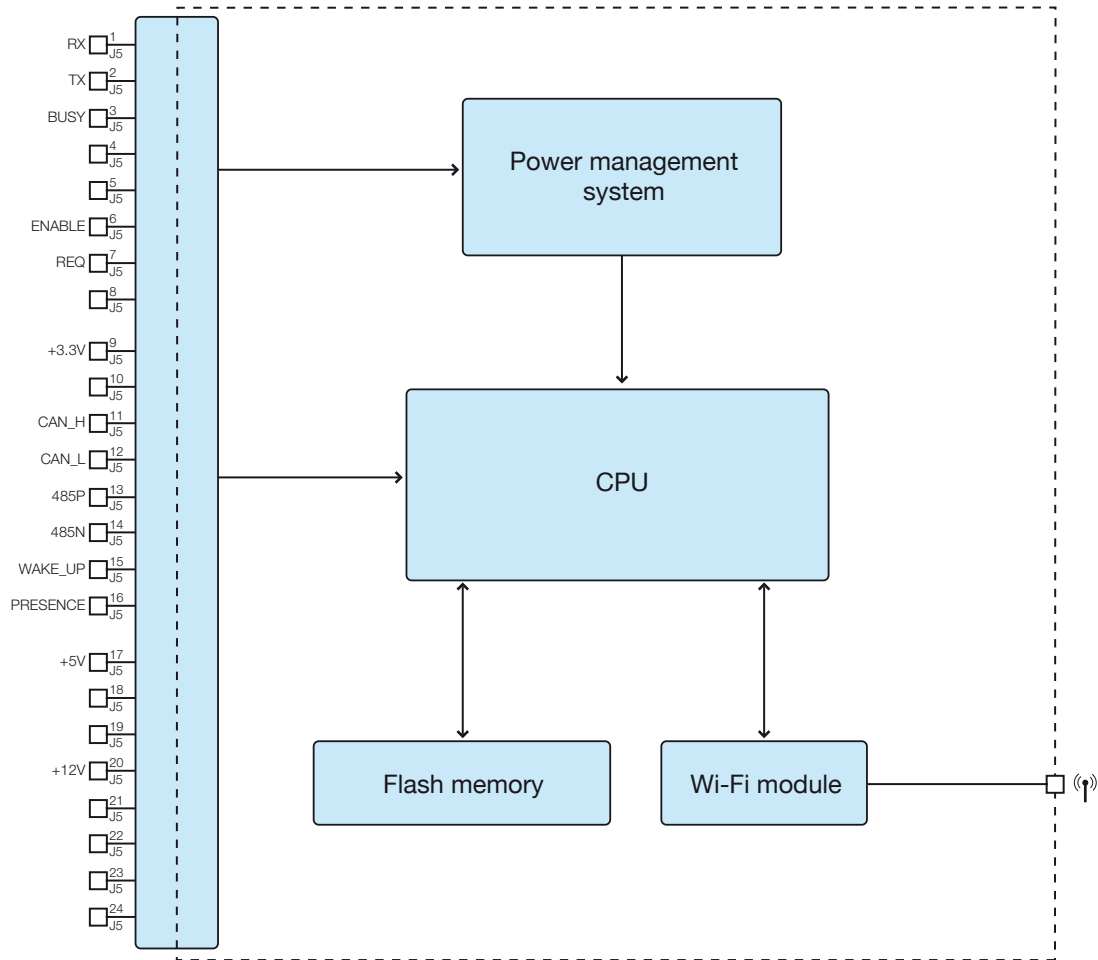

Support and service

ABB supports its customers with dedicated, global service organization in more than 60 countries and strong regional and national technical partner networks providing complete range of life cycle services.

For more information please contact your local ABB representative or visit:

www.abb.com/solarinverters

www.abb.com

© Copyright 2014 ABB. All rights reserved.
Specifications subject to change without notice.

